User Manual

LDM301

Firmware Version from 1.5

Version 1.5



CE

Dear User,

You are advised to carefully read this User Manual before turning on the LDM 301 Laser Distance Meter for the first time.

This is necessary to ensure that you will be able to use all the capabilities and features provided by your new purchase.

This product is subject to ongoing technological developments.

Editorial deadline: May 2011

Manual version: V 1.5.04

Firmware version: from 1.5

Note:

Proper care has been used in compiling this document. No liability will be accepted in the event of damage resulting from the failure to comply with the information contained herein.

Contents

1	General information	9
2	Safety advice	10
2.1	Basic safety advice	10
2.2	Safety advice for operating the laser	11
2.2.1	Safety advice for laser class 1 – Measurement Laser	11
2.2.2	Safety advice for laser class 2 – Pilot Laser	11
2.3	Advice for operating the device	13
2.4	Norms	14
2.5	Disposal	14
3	Operating conditions	15
3.1	Electrical installation conditions	15
3.2	Operating and storage conditions	15
3.3	Appropriate use	16
3.4	Improperly use - Error sources	17
4	Device description	18
4.1	General device description	18
4.2	Technical Data	19
4.3	Device Types	21
4.4	Laser divergence	22
4.4.1	LDM301 with 1.7 mrad (Standard)	22
4.4.2	LDM301 with 10 mrad (Option)	23
4.5	Functional Elements	24
4.6	Mechanical Integration Requirements	25
4.7	Connector Pin Assignments	26
4.7.1	Main Connector Port (M18)	26
4.7.2	SSI Port of LDM301S (M12)	27
4.7.3	Profibus Port of LDM301P (M12)	28
4.8	Status Display	28
4.9	Pilot Laser	30
5	Interface Description	31
5.1	RS232 or RS422 interface	31
5.1.1	Transmission Protocol	31
5.1.2	Wiring of RS232/RS422	34
5.2	Q1 and Q2 Switching Outputs	34
5.3	Analogue output QA	35

5.4	Trigger Port.....	37
5.5	SSI Interface of LDM301S	39
5.5.1	Specification.....	39
5.5.2	Electrical Connection SSI	39
5.6	Profibus Interface of LDM301P.....	40
5.6.1	General	40
5.6.2	Installation conditions.....	40
5.6.3	GSD File	40
5.6.4	Slave Address.....	40
5.6.5	Bus Termination.....	41
5.6.6	Baud Rate	41
5.6.7	Segment Length.....	41
5.6.8	Profibus Electrical Connection	42
5.6.9	Profibus-Parameter.....	42
5.6.10	Diag Common	45
5.6.11	Diag Alarm	45
5.6.12	Diagnostic Data.....	45
5.6.13	Cyclic data exchange – Input (Slave → Master)	47
5.6.14	Cyclic data exchange – Output (Master → Slave)	47
6	Installation.....	49
6.1	Preparation Work before the Installation	49
6.2	Checklist for Installation Works	49
7	Description of Commands.....	51
7.1	Identification.....	51
7.1.1	ID –Identification	51
7.1.2	ID? – Online-Hilfe.....	51
7.2	Operation Mode	52
7.2.1	DM – Single distance measurement.....	52
7.2.2	DT – Continuous distance measurement	52
7.2.3	DF – Measure single distance with external triggering ..	52
7.2.4	VM – Single speed measurement.....	52
7.2.5	VT – Continuous speed measurement	53
7.2.6	Precision of the speed measurement	53
7.3	Status.....	54
7.3.1	TP – Internal device temperature	54
7.3.2	PA – Display of all parameters.....	54
7.3.3	HW – Hardware diagnosis	54
7.4	Setup Parameter.....	55
7.4.1	AS – Auto start function	55

7.4.2	PL – Pilot Laser.....	56
7.4.3	PR – Reset to factory settings	56
7.4.4	DR – Release cold start.....	57
7.4.5	SF – Scaling factor.....	57
7.4.6	OF – Offset.....	57
7.4.7	SO – Set offset.....	57
7.4.8	MW – Measurement window	58
7.4.9	MF – Measurement frequency [Hz].....	58
7.4.10	SA – Average value	59
7.4.11	TD – External trigger delay / level / mode.....	60
7.4.12	SE – Error Mode	60
7.4.13	Q1/Q2 – Switching output.....	61
7.4.14	QA – Analogue output.....	62
7.4.15	BR – Baudrate	63
7.4.16	SD - Output format serial interface	63
7.4.17	TE – Terminator for the serial interface	65
7.4.18	SC – Format SSI.....	65
7.4.19	HE – Threshold heating	66
8	Maintenance.....	67
8.1	Maintenance by the user.....	67
8.2	Firmware Update	67
8.3	Repair	67
9	Malfunction & Error Messages.....	68
9.1	Malfunction.....	68
9.2	Error Codes	68
9.3	Error Status.....	68
10	Options	69
10.1	RS232 Cable.....	69
10.2	Connection box TCBLDM.....	70
10.3	Adjustment bracket.....	70
10.4	Dot Sight AD30	70
10.5	Adapter plate.....	71
10.6	Dust protection tube.....	72
10.7	Protection Housing.....	73
10.8	Software LDMTTool	74
11	Order Codes	75
12	EC Declaration of Conformity.....	76

Figures

Figure 1 Device warning sign	12
Figure 2 Position of the device warning sign	12
Figure 3 Beam diagram for LDM301 with 1.7 mrad.....	22
Figure 4 Beam size for LDM301 with 1.7 mrad	22
Figure 5 Beam diagram for LDM301 with 10 mrad.....	23
Figure 6 Beam size for LDM301 with 10 mrad	23
Figure 7 Functional Elements	24
Figure 8 Dimensions and position of the zero point (in mm)	25
Figure 9 Connection drawing of the main connector	26
Figure 10 Connection diagram LDM301S SSI.....	27
Figure 11 Connection diagram LDM301P Profibus-IN	28
Figure 12 Connection diagram LDM301P Profibus-OUT	28
Figure 13 Status Display.....	28
Figure 14 Pilot Laser position relative to measurement laser.....	30
Figure 15 Wiring of serial interface.....	34
Figure 16 Switching characteristics of outputs	34
Figure 17 Example of switching output wiring	35
Figure 18 Signal diagram of LDM 301 analogue output	36
Figure 19 Example of LDM 301 analogue output wiring.....	36
Figure 20 Example for the external wiring of the trigger input	38
Figure 21 Interconnection of several LDM301 devices.....	38
Figure 22 SSI connection diagram LDM301S M12 connector.....	39
Figure 23 Profibus connection diagram LDM301P M12 connector	42
Figure 24 Program LDMTool	50
Figure 25 Online Help (Command ID?)	51
Figure 26 Display of all parameters (command PA).....	54
Figure 27 Parameter reset (command PR)	56
Figure 28 PC-Interface cable with power supply	69
Figure 29 Red dot sight.....	70
Figure 30 Adapter plate	72
Figure 31 Dust protection tube	73
Figure 32 Protection Housing	73

Tables

Table 1 Electrical installation conditions 15

Table 2 Technical data 20

Table 3 Device types 21

Table 4 Pin assignments of main connector port 27

Table 5 Status display - functions 29

Table 6 Command summary 33

Table 7 Profibus baud rate depending on segment length 41

Table 8 Profibus cable type A features 42

Table 9 Explanation Profibus parameters..... 43

Table 10 Profibus parameter 44

Table 11 Profibus diagnostic data length..... 45

Table 12 Profibus diagnostic data 46

Table 13 Profibus Input..... 47

Table 14 Profibus Output..... 47

Table 15 Installation of LDM301 49

Table 16 Standard deviation for speed measurement..... 54

Table 17 Description for hardware diagnosis 55

Table 18 Pilot laser PLx, x value..... 56

Table 19 Streuung Entfernungsmessung 59

Table 20 Error Mode SEx, values for x..... 61

Table 21 Function of the switching outputs under different modes 62

Table 22 Serial output format SDy, parameter y 64

Table 23 Termination character(s) TEx, parameter x..... 65

Table 24 Malfunctions..... 68

Table 25 Error codes 68

Table 26 Error status 68

Table 27 Connection of programming cable PC sided 69

Table 28 Connection of programming cabiLDM301 sided 69

Used Symbols



The sign Laser warns against emitting visible and invisible laser radiation.



The sign warns of danger of electrical power and of electric shock.



The sign warns of danger.



The sign shows information for use in hazardous environments.



This sign indicates important information on the use of the device.



The sign shows the Protection Class 3 (protective with low voltage supply).



The sign indicates the degree of protection (IP) of the device.



This sign informs that special guidelines apply for the disposal of the device.

1 General information

The laser distance measurement device LDM301 is developed for industrial applications. It enables the non-contact measurement of distances and speed with a precision down to the centimeter. The device measures with short measurement time onto any diffusely reflecting target surface also without using a reflector.

Depending on the type, two switching outputs and the following interfaces are available: RS232, RS422 and analogue output, SSI or Profibus. The device is easy to install and operate. An LED display on the rear side of the device enables the user to monitor the device in operation.

The compact and rugged design, the easy installation, low current consumption, adjustable switching outputs and the possibility to set user specific parameters are important features of the LDM 301. The features of the device enable a number of applications in industrial environment:

- Process surveillance in steel and roller plants
- Fill level measurement
- Surveillance of object movements
- Positioning of cranes and loading facilities
- Measurement of inaccessible measurement areas, e.g. in hollow spaces, tubes and containers
- Position surveillance of vehicles and ships

As standard, the LDM301 is equipped with integrated heating, status display and a sight mechanism. The alignment to the measurement objective is easy by the red laser dot of the pilot laser

The modular construction of the device enables the easy upgrade with additional equipment or the customization for specific applications.

The device operates on the basis of time of flight measurement. Short laser pulses are transmitted. The light pulse reflected from the target is detected by the receiver. The distance can be determined by the time shift.

The measurement range depends on the reflectivity and the surface of the measuring target.

2 Safety advice

2.1 Basic safety advice

Please read the safety and operating advice carefully, and observe the advice when operating the LDM301 laser distance measurement device.



Danger, laser radiation

The LDM301 unauthorized operation is not allowed, otherwise laser radiation can be emitted that can cause injuries to the eyes. Please observe all information and guidelines for operating the laser.



Danger, electric shock

The LDM301 may only be opened for repair purposes by the manufacturer. If the device is opened arbitrarily without authorization, all warranty claims will expire.



The **operating and storage conditions** have to be observed (see chapter 3). The non-observance of this advice and the adverse use of the device can lead to injuries of the user or to damage of the device.



Connectors may not be plugged or unplugged when voltage is applied. All installation work may only be carried out when no voltage is applied.



The device may only be **operated as intended** and in faultless condition.

Safety installations must not be rendered ineffective.
Safety and warning signs must not be removed.



Protection Class 3, low voltage

The device is operating with voltage of 10 to 30 volts.



Protection degree: In accordance with the **Protection Degree IP67**, the LDM301 is protected against jet water and dust, and against short submersion into water.

When operating the device under extreme outdoor environmental conditions, the use of additional weather

protection is recommended (e.g. a cover plate with a short distance to the LDM301). Rapid temperature changes can lead to humidity entering the device.



The device is **not shatter-proof**. Do not let the device fall onto the ground, and avoid any shock.

The device is delivered in a solid cardboard box, which is suited for the transport of the device.



The device may **not be used in explosive environments**; otherwise there is the danger of damage to the LDM301 and the surrounding equipment, and of injuries of the user.

2.2 Safety advice for operating the laser

The LDM 301 is equipped with two lasers:

Laser for measurement (invisible)	-	Laser Class 1
Pilot Laser (visible red)	-	Laser Class 2

For both laser classes, different safety guidelines apply. Please observe the advice for every laser class.

2.2.1 Safety advice for laser class 1 – Measurement Laser



The measurement laser is a class 1 laser device based on the norm IEC 60825-1:2003 (Safety of laser products – Part 1: equipment classification and requirements).

The laser radiation of class 1 lasers does not imply any danger to the human eye; any injury of the human eye can be excluded.

2.2.2 Safety advice for laser class 2 – Pilot Laser



The pilot laser is a class 2 laser device based on the norm IEC 60825-1:2007 (Safety of laser products – Part 1: equipment classification and requirements).

The Laser power is limited to maximum 1 mW. The Laser radiation is visible. A short-term exposure (duration up to 0.25 s) is harmless to the eye.

Safety advice

Users are instructed by Laser warning sign (see Figure 1) to do not stare into the beam. They have to protect themselves by turn the head and/or closing the eyes and by avoid a long look into the beam.
The sensor can be used without any additional safety protection.



Danger: Laser radiation Class 2, do not stare into the Laser beam! Do not look into the Laser beam with optical instruments. Do not direct the Laser beam onto persons.



Figure 1 Device warning sign ¹

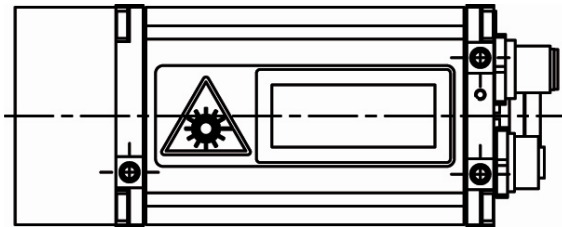

Figure 2 Position of the device warning sign ²

After the commissioning the pilot laser can be disabled with the command PL0 (see 7.4.2 PL – Pilot Laser). During the measurement the pilot laser is turned off automatically. To turn the pilot laser on set PL <> 0 and the measure have to break with ESC if necessary.

¹ The devices of the LDM301 series can vary with regard to the divergence of the laser diode and the maximum measurement frequency displayed on the laser labels.

² A second laser warning sign is inside the delivery. It is to be attached to the installation place and must be easy to view for the operator.

2.3 Advice for operating the device



The LDM301 must not be operated when optical parts are soiled or clouded. The lenses of the device must not be touched with bare hands!

Dust and dirt have to be removed from the optical components with caution!



The device must be protected against overheating. The device will not be switched off automatically when the operating temperatures are exceeded. The persisting overheating of the device will lead to a reduced lifetime of the laser diode.



The device must be protected from impact. The device must be protected from extreme temperature fluctuations. When extreme temperature fluctuations are occurring use additional protection housing.



It is not allowed to operate the device in explosive environments.



The device corresponds to the protection degree IP 67, and is protected against jet water and short submersion. Please observe the conditions for the protection degree IP 67, and observe especially the following advice:

- The device must not be exposed to persisting driving rain or high temperature variations.
- If the device is exposed to humidity, the temperature difference between the device and the environment may be $\pm 5\text{K}$ maximum.



It is necessary to observe the operating and storage conditions.

Use only a supply voltage of 10 V ... 30 V DC (direct current voltage). For using the heating, direct current voltage of 24 V is recommended.

The limit values for the input voltage have to be observed. Do not wire inputs as outputs.

All outputs are resistant to short circuits. The housing is galvanically separated from the sensor electronics assembly. The interference resistance at electrostatic discharge (ESD) is 4 kV according to EN 61326-1.

2.4 Norms

The device conforms to the following norms:

- | | |
|------------------|---|
| IEC 61326-1:2005 | Electrical equipment for measurement, control and laboratory use - EMC requirements - Part 1: General requirements (IEC 61326-1:2005); German version EN 61326-1:2006 |
| IEC 60825-1:2007 | Safety of Laser products – Part 1: equipment classification and requirements (IEC 60825-1:2007)
Laser Class 1 (Measurement Laser)
Laser Class 2 (Pilot Laser) |
| EN 61010-1:2001 | Safety requirements for electrical equipment for measurement, control and laboratory use - General requirements (IEC 61010-1:2001); German version EN 61010-1:2001 |

2.5 Disposal



For the disposal of the device, special environmental protection guidelines apply. Do not dispose the device with the usual domestic refuse. The manufacturer offers to take back the device after the end of the product life cycle, and to dispose of the product in accordance with the effective environmental protection guidelines. Please note that this service is subject to a charge.

3 Operating conditions

3.1 Electrical installation conditions

Use only a supply voltage of 10 V ... 30 V DC (direct current voltage).
For using the heating, direct current voltage of 24 V is recommended.



The limit values for the input voltage have to be observed. Do not wire inputs as outputs.

All outputs are short circuits proof.

The housing is galvanically separated from the sensor electronics assembly.

The interference resistance at electrostatic discharge (ESD) is 4 kV according to EN 61326-1.

Electrical installation conditions	
Supply voltage	10 V ... 30 V DC (direct current voltage) ³
Current consumption	< 5 W (without heating) 11,5 W (with heating, 24 V)

Table 1 Electrical installation conditions

3.2 Operating and storage conditions

Operating temperature: - 40 °C ... +60 °C

Storage temperature: - 40 °C ... +70 °C

Air humidity: 15 % ... 90 %



The mentioned **operating and storage conditions** have to be observed. When the operating temperatures exceed the permitted values, the device will not be switched off automatically. The continuous overheating of the device will reduce the lifetime of the laser diode.

³ For using the heating, direct current voltage of 24 V is recommended.

3.3 Appropriate use

The device is intended for the following applications:

Distance and speed measurement, and display of the measurement data via the interfaces RS232, RS422, analogue output, SSI or Profibus.

- Use of the special measurement functions
- Operation with the correct voltage
- Observing the environmental conditions, operating and storage temperature
- Use in industrial environments complying with the standard IP67 (protected against splash and jet water)
- Control of the data interfaces using the indicated signal levels



Measurement through optically transparent material

Measurement through optically transparent materials such as glass, optical filters, acrylic glass etc. can lead to erroneous measurement results. When measuring through optically transparent material, use the function “measurement window”. By defining a fixed measurement range using this function, the display of an erroneous measurement value caused by the optical medium in front of the laser can be avoided. Please take care that the surface of the medium is clean and light-transparent.



Measuring distances < 8 m

Due to the optical system of the receiver, the device LDM301 with a divergence of 1.7 mrad receives only scattered light at distances < 8 m. Therefore, measurement in this range is only possible onto targets with good reflective properties. As an alternative, an LDM301 with 10 mrad can be used, as this device does not imply any restrictions for distance measurement.

3.4 Improperly use - Error sources

The device may only be used when the safety advice described in chapter 2 are observed. The non-observance of the safety advice can lead to damages of the device or to injuries of the eyes.

To achieve correct measurement results, avoid the following error sources:

- Measurement against the sun and other intense light sources
- Measurement onto low reflective target surfaces in highly reflective environments
- Measurements onto highly reflective surfaces (mirror)
- Rapidly-changing measurement conditions (rapid distance changes)
- Two or more LDM301 may not be "frontal view" because the devices interact. To avoid false readings, the devices must be successively raised. Use the trigger generator TPG1 (accessory) or the trigger function according to item 2 in chapter 5.4 (Interconnection of several LDM301).
- Operation and storage of the device under conditions that do not conform with the specifications
- Overheating



The operating temperatures have to be observed. The overheating of the device has to be avoided in any case. When the operating temperatures are exceeded, the device is not switched off automatically. Persisting overheating of the device leads to a reduced lifetime of the laser diode.

4 Device description

4.1 General device description

The laser distance measurement device LDM301 is intended for distance measurement onto static and moving objects with a precision down to the centimetre:

- Measurement in the range of 0.5 m ... 300 m onto natural surfaces with 90 % reflectivity.
- Measurement onto reflectors (e.g. Scotchlite 3000x) at distances between 300 m ... 3000 m.
- For speed measurement in the range of 0 m/s ... 100 m/s (distance 0.5 m ... 700 m).



For measuring distances < 300 m, the use of glass reflectors (triple mirrors) is not recommended, as a distortion of measurement values can be caused by overload.

Pilot Laser

With the red laser measurement spot (pilot laser), the measurement target can be clearly identified. The range depends on the reflectivity and the surface properties of the measurement target.

Serial interfaces

The LDM301 is equipped either with an RS232 or with an RS422 interface. The device configuration is carried out during the assembly. The device cannot be changed retroactively.

Outputs

The device is equipped with two switching outputs, an analogue output (4 ... 20 mA) and an external trigger connection. All outputs are parameterizable.

Heating

When certain temperature thresholds are exceeded, the heating is switched on or off automatically.

Values preset in the factory: +4°C heating is switched on and +10°C heating is switched off. The values can be specifically configured by the user (refer to chapter 7.4.19, "HE – Threshold heating").

4.2 Technical Date

Measurement properties	
Measurement principle	Laser pulse time of flight measurement
Measurement range ⁴	0.5 m ... 300 m onto natural surfaces ⁵ 300 m ... 3000 m onto target board ⁶
Measurement precision	± 20 mm (measurement value output 100 Hz; measurement frequency 2kHz) ± 60 mm (measurement value output 2 kHz)
Measurement value resolution (distance)	1 mm
Measurement time for distance	Standard: 0.5 ms Special version: 0.1 ms
Measurement range for speed ⁷	0 ms ⁻¹ ... 100 ms ⁻¹
Measurement time for speed	0.1 s ... 0,5 s

Laser	
Laser for measurements	Laser Class 1 (infrared, non visible) Laser beam divergence Standard: 1,7 mrad Option: 10 mrad, Wavelength 905 nm
Pilot Laser	Laser Class 2 (red, visible) Wavelength 635 nm

Electrical installation conditions	
Supply voltage	10 V ... 30 V DC
Power consumption	< 5 W (without heating) 11,5 W (with heating @ 24 V)

⁴ depends on the reflection properties of the target, ambient light influence and atmospherically conditions

⁵ natural, diffusely reflecting surfaces, under 10 m don't use low reflective materials (dark/black surface) for target

⁶ e.g. Scotch Lite 3000x

⁷ Distance range: 0.5 m ... 700 m

Interface / Connections	
Interfaces	1x 12-pole (BINDER Series 723) M18 2x 5-pole (BINDER Series 766) M12 B-coded ⁸
Serial interfaces	RS232 or optionally RS422, 9,6... 460,8 kBaud, format: 8N1, ASCII
Profibus (LDM301P)	DP-V0 Slave IEC 61158 / IEC 61784 9,6 kBaud ... 12 Mbaud, auto detect, termination resistor extern, slave address can be set via Profibus
SSI (LDM301S)	50 kHz ... 1MHz, 25 µs pause 24bit, binary or gray-coded can be set
Switching output	2x "High-Side-switch", load up to 0.2 A, permanent short circuit protected, adjustable window function
Analogue output	4 mA ... 20 mA ⁹
Trigger for device synchronization	1x Trigger In/Out, edge and delay adjustable, trigger level 3 ... 30 VDC,
Operating modes	single measurement continuous measurement, mean value, external triggering (adjustable near field suppression and window function)

Environmental and application conditions	
Operating temperature	-40 °C ... +60 °C
Storage temperature	-40 °C ... +70 °C
Air humidity	15 % ... 90 %
Dimensions (LxWxH)	136 mm x 57 mm x 104 mm
Weight	ca. 800 g (depending on the equipment)
Protection degree	IP 67
EMC	IEC 61326-1:2005

Table 2 Technical data

⁸ only LDM301P and LDM301S

⁹ Total output error for 20mA: + 0,15 % @ temperature +25 °C

4.3 Device Types

The LDM301 is available in different designs and with different interfaces. The following devices are available:

Type	LDM301A/RS232	LDM301A/RS422	LDM301P	LDM301S
Serial Interface	RS232	RS422	RS232	RS232
Analogue output	Yes	Yes	Yes	Yes
Profibus	-	-	Yes	-
SSI	-	-	-	Yes

Table 3 Device types

In addition, the devices can be ordered - depending on the measurement task - with the following features¹⁰:

- Increased maximum measurement frequency, 10 kHz instead of the standard of 2 kHz
- Laser with increased divergence, 10 mrad instead of standard 1.7 mrad

¹⁰ not with LDM301S and LDM301P

4.4 Laser divergence

The LDM301 is available in two different versions with respect to the laser divergence.

4.4.1 LDM301 with 1.7 mrad (Standard)

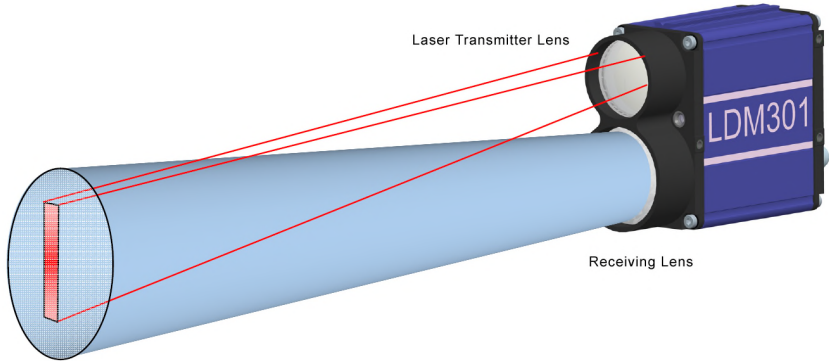

Figure 3 Beam diagram for LDM301 with 1.7 mrad

The divergence of the laser is 1.7 mrad x 0.08 mrad (rectangle). The receiver divergence is 2.9 mrad (circle).

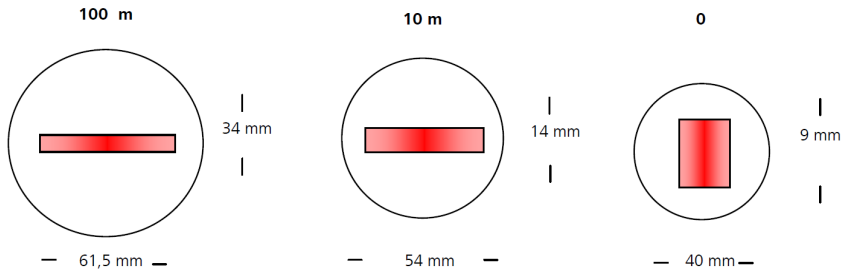

Figure 4 Beam size for LDM301 with 1.7 mrad

4.4.2 LDM301 with 10 mrad (Option)

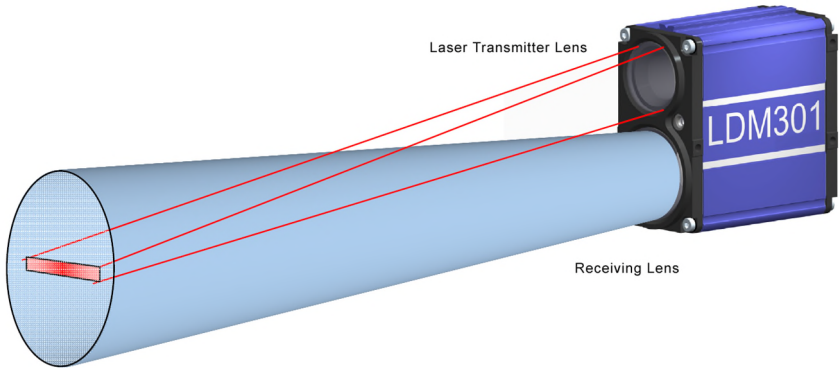

Figure 5 Beam diagram for LDM301 with 10 mrad

The divergence of the laser is 10 mrad x 0.5 mrad (rectangle). The receiver divergence is 14.3 mrad (circle).

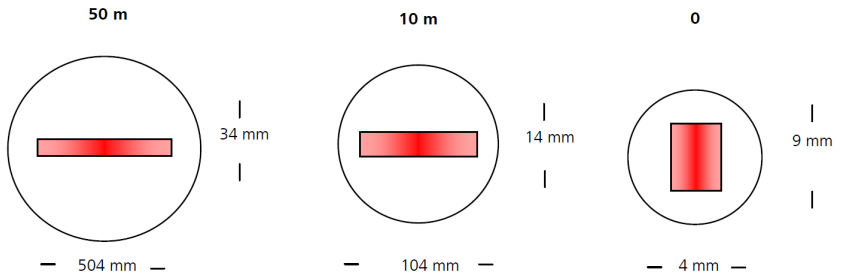
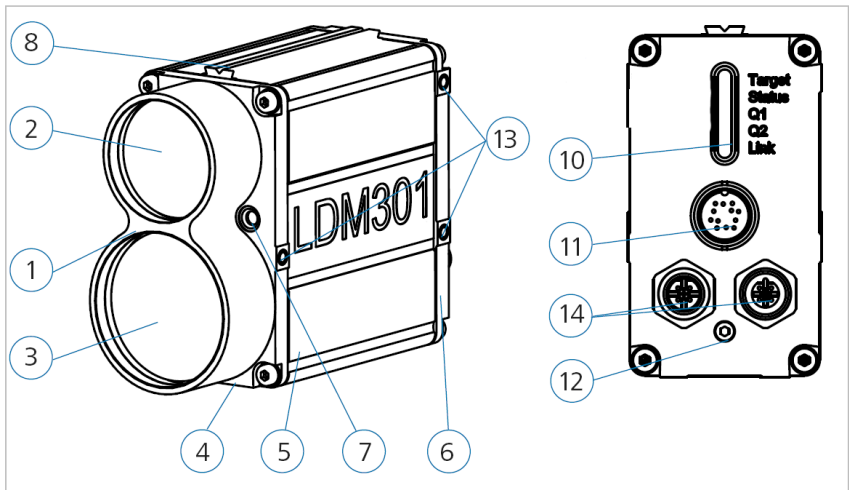

Figure 6 Beam size for LDM301 with 10 mrad

4.5 Functional Elements

The casing consists of a robust, corrosion-resistant extrusion-molded aluminum structure with a front cover plate and a back cover plate equally corrosion-resistant.

On each lateral side and on the underside of the LDM 301 casing there are three support pads with mounting holes (M4) for mechanical attachment of the LDM 301 (see Figure 8).



- | | | | |
|---|--------------------|----|--------------------------|
| 1 | Front tube | 8 | 11 mm-rail |
| 2 | Transmitter optics | 10 | Status display |
| 3 | Receiver optics | 11 | Main connector (M18) |
| 4 | Front cover plate | 12 | Service screw |
| 5 | Casing | 13 | Support pads with M4 x 6 |
| 6 | Back cover plate | 14 | optional connectors |
| 7 | Pilot Laser | | Profibus or SSI |

Figure 7 Functional Elements

4.6 Mechanical Integration Requirements

For integration of the LDM301 Laser Distance Meter, three different versions of mechanical attachment are available.

1. Attachment to a lateral surface: For attachment to the lateral surfaces, the LDM301 provides three support pads (Figure 8) with mounting holes (M4 x 6).
2. Attachment to casing bottom: Likewise, the LDM301 provides three support pads (Figure 8) with mounting holes (M4 x 6) for attachment to the bottom face of its casing.
3. Attachment via adapter plate (replacement of LDM300C): To replace an LDM300C with an LDM301, an adapter plate is required. This plate must be screwed to the bottom side of the LDM301.

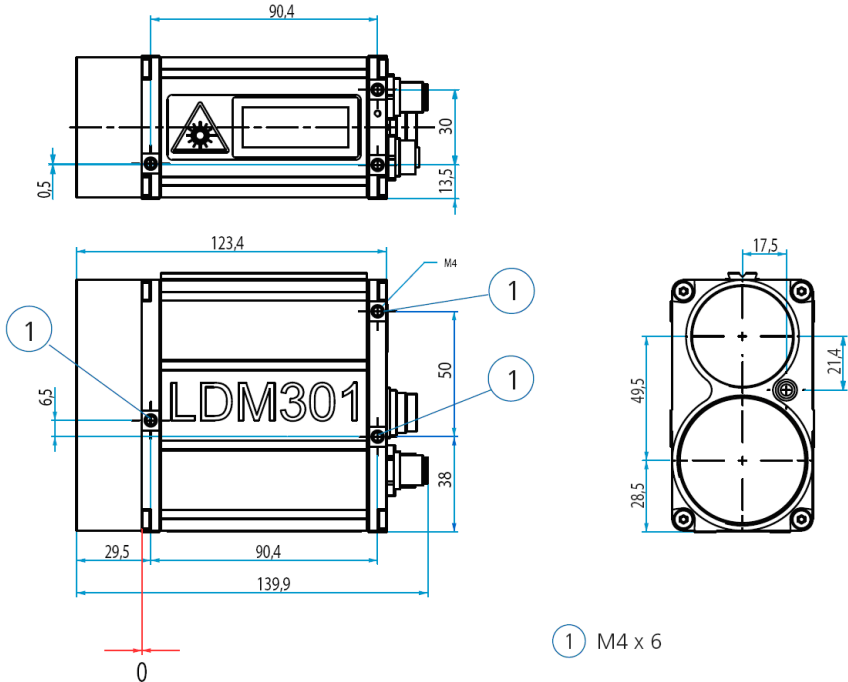

Figure 8 Dimensions and position of the zero point (in mm)

The zero point of LDM301 corresponds to the external surface of the front cover.

4.7 Connector Pin Assignments

Depending on the implemented configuration version of the various LDM 301 models, different terminal facilities are available for connections. All models share the same type of main connector port.

4.7.1 Main Connector Port (M18)

The main connector port (see Figure 7 Functional Elements, no. 11) includes the terminal points for voltage supply, for serial data communication (RS232 or RS422), for the two switching outputs (Q1 and Q2), one analogue output (QA) and for one trigger port (TRIG). A shielded cable must be used for connection. This cable is included in delivery.



Figure 9 Connection drawing of the main connector



Heed cable colours: blue – VCC and gray/pink – GND!
Please use only high quality shielded cable.

Pin	Colour code of cable	RS232	RS422	Description
A	White	TxD	RX+	RS232 send data / RS422 receive data +
B	Brown	RxD	RX-	RS232 receive data / RS422 receive data -
C	Green	TRIG	TRIG	Trigger port
D	Yellow	QA	QA	Analogue output (4 ... 20 mA)
E	Grey	TX-	TX-	RS422 send data -
F	Pink	TX+	TX+	RS422 send data +
G	Blue	VCC	VCC	Supply voltage
H	Red	n.c.	n.c.	not connected
J	Black	GND	GND	GND
K	Violet	Q2	Q2	Switching output Q2
L	Grey/pink	GND	GND	GND
M	Red/blue	Q1	Q1	Switching output Q1

Table 4 Pin assignments of main connector port

4.7.2 SSI Port of LDM301S (M12)

The connection to the SSI interface of the LDM301S is accomplished via a 5-pole, B-encoded M12 male connector. Shielded cables should be used for connection. The second M12 connector is not used.

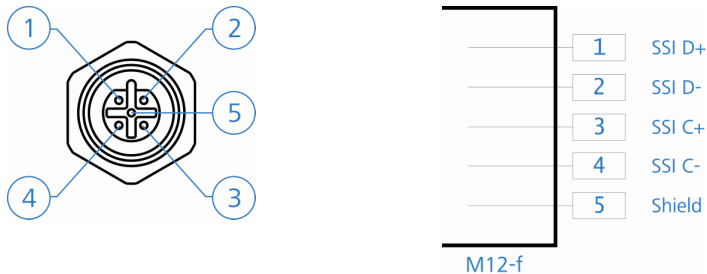

Figure 10 Connection diagram LDM301S SSI

4.7.3 Profibus Port of LDM301P (M12)

For Profibus connection there are 3 B-encoded 5-pole M12 connectors. The connection must be made with Profibus conform cables.

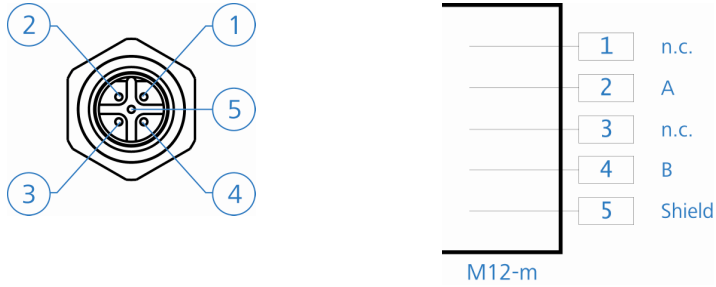

Figure 11 Connection diagram LDM301P Profibus-IN

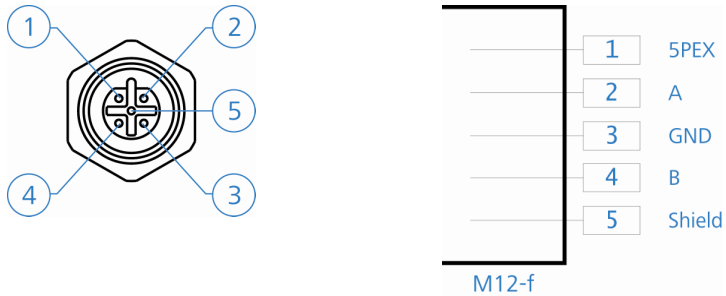

Figure 12 Connection diagram LDM301P Profibus-OUT

4.8 Status Display

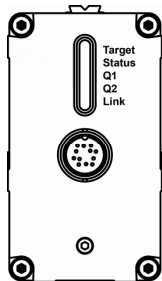

Figure 13 Status Display

Device description

LED	Function	Display	Status
Target	Reflectivity	Off Red blinking Red Yellow Green Green blinking	No signal Very weak signal Weak signal Signal available Good signal Very good signal
Status	Readiness for action	Off Red Green	No operating voltage Technical defect Voltage supplied, Ready for action
Q1	Switching output 1	Off Yellow	Off Operating voltage supplied
Q2	Switching output 2	Off Yellow	Off Operating voltage supplied
Link	Status interface	Off Red Yellow Green	No field bus Profibus error Operating voltage supplied, Profibus inactive Operating voltage supplied, Profibus working

Table 5 Status display - functions

4.9 Pilot Laser

The pilot laser (see Figure 8, no. 7) is intended to support alignment to a given target point during start-up action of the LDM 301. It qualifies as a Class 2 Laser device and operates at 635 nm (red) in the visible range. The pilot laser is not aligned to emit in a direction parallel with the measurement Laser. Instead, its beam intersects with that of the measurement Laser at a distance of 75 m.

Figure 14 shows the tolerance on pilot laser position in relation to the invisible measurement laser as a function of the distance to an object being measured:

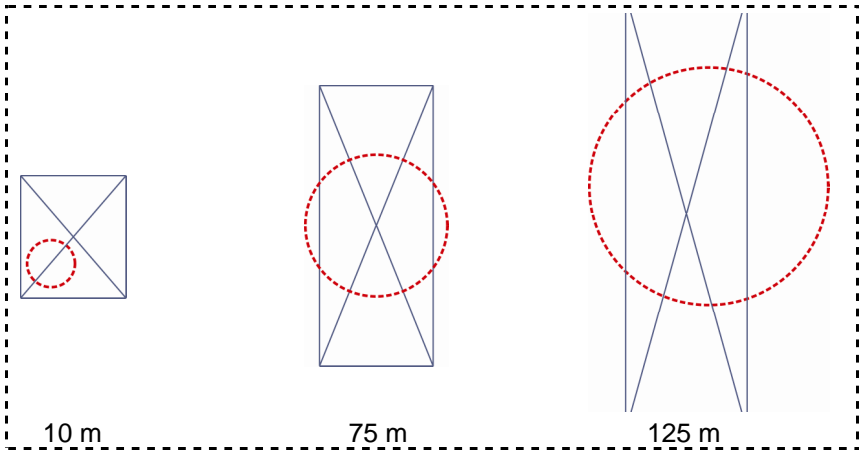

Figure 14 Pilot Laser position relative to measurement laser

5 Interface Description

For interfacing, the LDM 301 provides different connectors depending on the type (see chapter 4.3 Device Types). A main connector port (Figure 8, no. 11) is used for RS232- or RS422-interface and analogue output and additional connectors provide SSI interface (Figure 9, no. 3) or Profibus interface (Figure 9, no. 4, 5).

5.1 RS232 or RS422 interface

5.1.1 Transmission Protocol

- Interface settings: asynchronous, 8 data bits, no parity, 1 stop bit
- Communication protocol format/syntax: 7-bit ASCII
- Proprietary communication protocol
- Commands are not case-sensitive (no distinction between small lettering and capital lettering).
- Period "." (0x2E) serves as decimal separator for output of numbers.
- Enter (0x0D) is used as command (send command) termination character.
- With multi-value parameters, space (0x20) is used between each two values.
- A parameterization command with new parameters triggers a response command with these parameters.
- A parameterization command without new parameters triggers a response command with (most recent) parameters.
- A parameterization command with parameters out of valid setting ranges triggers a response command with (most recent) parameters.
- An unknown command and a faulty parameter format are quitted with "?" (0x3f).

Interface Description

Command group	Command	Description	Standard(s)	Range(e)
Operation Mode	DM	Single distance measurement	-	-
	DT	Continuous distance measurement	-	-
	DF	Single distance measurement with external triggering	-	-
	VM	Single speed measurement	-	-
	VT	Continuous speed measurement	-	-
Status	TP	Internal device temperature in °C	-	-
	PA	All-parameter display	-	-
	HW	Hardware diagnosis	-	-
Setup Parameter	PR	Reset to factory settings	-	-
	DR	Triggers a cold start	-	-
	ASs	Auto start function	DT	ID, ID?, DM, DT, DF, VM, VT, TP, HW, PA, MF, TD, SA, SF, MW, OF, SE, Q1, Q2, QA, BR, SD, TE, BB, AB, SC, PL, AS
	MFx	Measuring frequency [Hz]	2000	1 ... 2000
	TDx y	External trigger delay [ms] and trigger level [edge]	00.00 0	0 ... 300.00 0 or 1
	SAx	Mean value	200	1...30000
	SFx	Scale factor	1	± 0.001 ... 10
	MWx y	Measuring window at beginning and end	0 5000.000	± float 32 ± float 32
	OFx	Distance offset end	0.000	± float 32
	SO	Single distance measurement and acceptance as distance offset	-	-

Interface Description

Command group	Command	Description	Standard(s)	Range(e)
	SEx	Error mode for Q1, Q2 and QA	1	0 ... 2
	QAx y	Analogue output with lower and upper limit	0 50.000	± float 32 ± float 32
	Q1w x y z	Q1 switching output with trigger threshold, switching range, hysteresis and switching state	2.000 5000 0.100 1	± float 32 ± float 32 ± float 32 0 or 1
	Q2 w x y z	Q2 switching output with trigger threshold, switching range, hysteresis and switching state	4.000 5000 0.100 1	± float 32 ± float 32 ± float 32 0 or 1
	BRx	Baud rate	115200	9600, 19200, 38400, 57600, 115200, 230400, 460800
	SDx y	Output format of serial interface	0 0	0 ... 2 0 ... 3
	TEx	Terminating character for output via serial interface	0	0 ... 9
	SCx	SSI format	0	0 ... 1
	PLx	Pilot Laser	0	0 ... 3
	HEx y	Heating	4 10	-60 ... 40 -60 ... 45 (x <= y)

Table 6 Command summary

5.1.2 Wiring of RS232/RS422

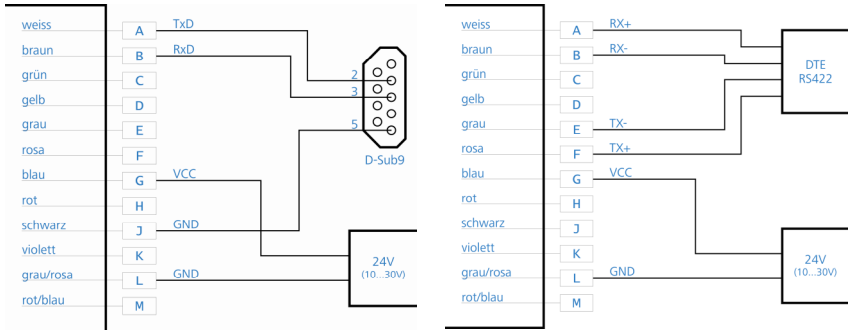

Wiring RS232 to D-Sub9

Wiring RS422 to RS422 unit

Figure 15 Wiring of serial interface

5.2 Q1 and Q2 Switching Outputs

The purpose of Q1 and Q2 is to represent distance readings as logic operation data. They report events of positive or negative exceeding of a preset switching range with a certain amount of hysteresis.

Accordingly, they are perfectly suited for direct reprocessing of monitored quantities such as filling level or for detection of objects. Parameter settings are made via the serial interface. The command to achieve this is Q1w_x_y_z (where “_” is equivalent to space (0x20)).

Value	Description	Specification
w	Trigger threshold	
x	Switching range	$x \geq 0$; $x \geq y$
y	Hysteresis	$y \geq 0$
z	Switching state	$z = 0$ or 1

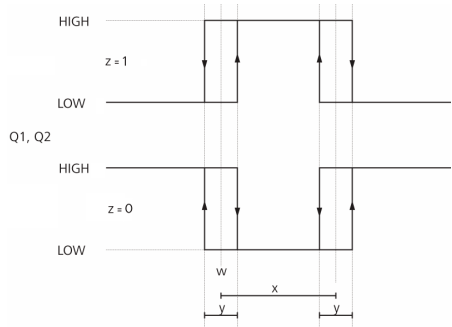

Figure 16 Switching characteristics of outputs

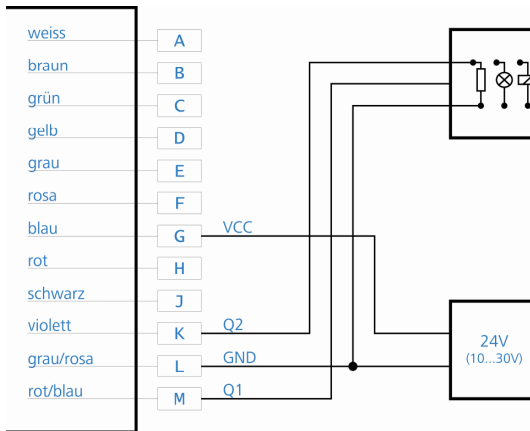

Figure 17 Example of switching output wiring

5.3 Analogue output QA

Properties of analogue output:

- 4 mA ... 20 mA
- value in case of an error: 3 mA or 21 mA or hold function for last value (depending on parameter SE)
- Resolution: 16 bit DA convertor
- Load: $\leq 500 \text{ Ohm}$

The analogue output allows standardized analogue data transfers from or to a remote location over greater distances using a two-wire transmission line. The current which is injected into this line at levels from 4 mA to 20 mA is proportional to the measured distance within a selectable distance interval. Parameter settings can be made via the serial interface.

Interface Description

The command to achieve this is QAx_y (where “_” is equivalent to space (0x20)). Parameter settings for current output in the event of measurement failure can be made using the command SEx.

Value	Description	Specification
x	Lower limit	$x \neq y$
y	Upper limit	$y \neq x$

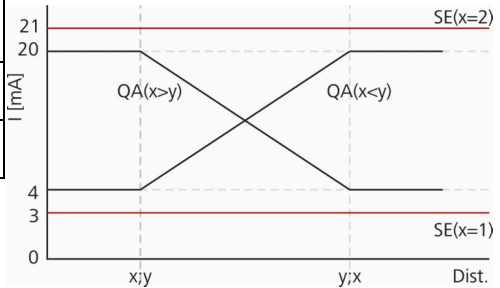

Figure 18 Signal diagram of LDM 301 analogue output

The value of output current (in mA) is calculated as follows:

$$x < y \quad QA \text{ [mA]} = 4 \text{ mA} + 16 \cdot \frac{Dist. - x}{y - x} \cdot \text{mA}$$

$$x > y \quad QA \text{ [mA]} = 20 \text{ mA} - 16 \cdot \frac{Dist. - y}{x - y} \cdot \text{mA}$$

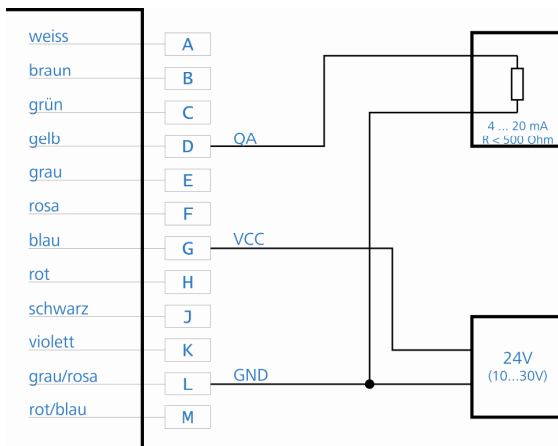

Figure 19 Example of LDM 301 analogue output wiring

5.4 Trigger Port

The trigger port allows two different uses:

1. Start a single distance measurement DF by an external signal in the form of a voltage pulse, the delay of the release trigger (trigger delay) and to triggered edge (trigger level) may be set.
2. Interconnection of several LDM301:
 - a) The first LDM301 is working as master in the mode DT or DM; when the laser impulse is started, a trigger signal is sent simultaneously.
 - b) The 2. LDM301 and further LDMs working as slaves in mode DF (Trigger input). They will start a measurement after the first LDM301. By a temporal delay between the measurements, which is adjustable with the trigger delay, interference between the devices can be excluded. The trigger frequency corresponds to the set frequency MF of the first LDM301.

Parameter TD:

z = 0 mandatory

x = delay is necessary¹¹; interference between the different LDM301 is avoided.

The parameterization of the trigger connection is carried out via the serial interface.

Command TDx_y. (“_“ corresponds to empty space (0x20))

The trigger function is only active in the measurement mode DF.

Voltage level for the trigger signals:

- Low level 0 – 1,5 V
- High level 3 – 30 V
- Threshold 2.25 V
- Hysteresis 0.1 V

¹¹ Depending on the measuring time (see also TD and SA)

Interface Description

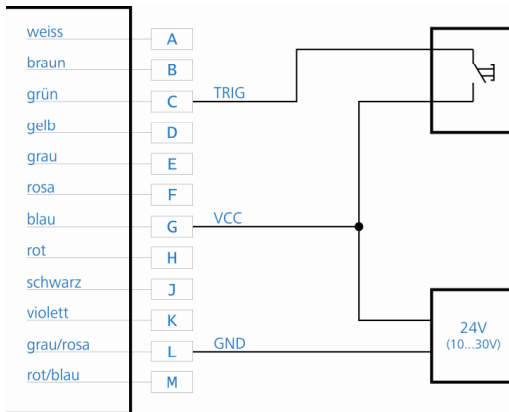

Figure 20 Example for the external wiring of the trigger input

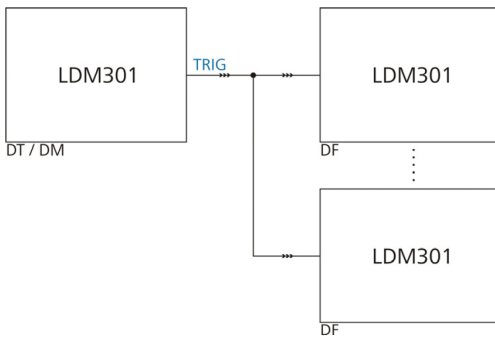

Figure 21 Interconnection of several LDM301 devices

5.5 SSI Interface of LDM301S

5.5.1 Specification

The LDM301S is equipped with an SSI-data interface (SSI = synchronous serial interface). By the SSI master the current measurement data is collected, it sends to the clock for the shift register in the slave. The SSI slave sends its data from the shift register bit by bit to the master. Depending on the length and quality of the data cable transfer rates of 50 kHz to 1 MHz at 25 microseconds interval time between two bit streams are possible.

The data length is 24 bits plus one validity bit. The format can be binary or gray-encoded. For parameter settings via the serial interface, the SCx command is available.

SCx x=0...binary, 25 bits (24 bits plus 1 validity bit)
 x=1...gray, 25 bits (24 bits plus 1 validity bit)

Bit stream:

24	23	2	1	0	
MSB	Bit 1 – 24 distance depending on preset scale factor				LSB	*)

*) Bit 0: validity bit

5.5.2 Electrical Connection SSI

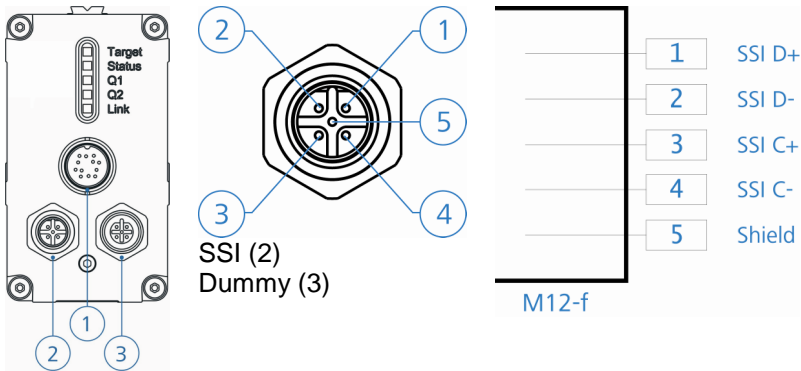

Figure 22 SSI connection diagram LDM301S M12 connector

5.6 Profibus Interface of LDM301P

5.6.1 General

LDM301P supports the Encoder-Profile of the Profibus (No. 3062 of the PNO). The LDM301P is used here as a linear encoder. As part of the encoder profile, the LDM301P can work as Class1 or Class2 (recommended) encoder. All variants are implemented via the GSD file. In addition to the specific profile data the LDM301P provide specific settings. These relate to the control of the laser and the diagnostic data. The LDM301P has the ID number 0AA2 (HEX).

5.6.2 Installation conditions

The LDM301 can be connected to each Profibus-DP structure. The corresponding Profibus DP Master must be able to send a parameterization telegram. The corresponding development tool (usually development software) must be able to support the display of the parameters in the device master file (GSD).

Parameters entered via the serial port are overwritten by the master at start-up by parameters of the field bus interface!

If the master does not send parameters the LDM301P starts with the stored parameters.

5.6.3 GSD File

The GSD-file has the name LDM301P2.GSD. The files LDM301P.dib and LDM301P.bmp belong to the GSD-file and serve for the display of the LDM301 in the projection tool. The integration of the files is described in the documentation of the projecting tool.

5.6.4 Slave Address

The Profibus slave address is adjustable subject to the other device in the range of 0 ... 125. The address is done by SSA-command of the Profibus. For information on how to change the slave address via the editing tool, you should consult the special editing tool documentation.

On delivery the address is 4 (alternatively, a label with the given address exists). The slave address is permanently stored in EEPROM and retained even after power failure.

If several slaves (LDM301P) are operated on a Profibus, please connect successively and set different addresses.

5.6.5 Bus Termination

For LDM 301 operation, an external bus terminator must be installed. Voltage supply of 5 V required for the terminator is available at Profibus-OUT. This 5 V supply is electrically isolated from general voltage supply (VCC) and rated for a current load up to 100 mA.

The terminating resistor is available as an accessory item.

5.6.6 Baud Rate

The LDM 301 provides automatic detection of the following baud rates: 9.6 / 19.2 / 93.75 / 187.5 / 500 k baud and 1.5 / 3 / 6 / 12 MBaud.

5.6.7 Segment Length

The maximum allowed segment length between to Profibus participants depends on the selected baud rate. The following rules on segment lengths must be fulfilled:

Baud rate [baud]	Segment length [m]
9.6 k – 93.75 k	1200
187.5 k	1000
500 k	400
1.5 M	200
3 M – 12 M	100

Table 7 Profibus baud rate depending on segment length

To comply with the segment rules, the use of cable type A is strongly recommended.

Parameter	Value
Wave resistance	135 ... 165 Ohm
Capacitance per unit length	< 30 pf/m
Loop resistance	< 110 Ohm/km
Cable wire diameter	> 0.64 mm
Cable wire cross-section	> 0.34 mm ²

Table 8 Profibus cable type A features

5.6.8 Profibus Electrical Connection

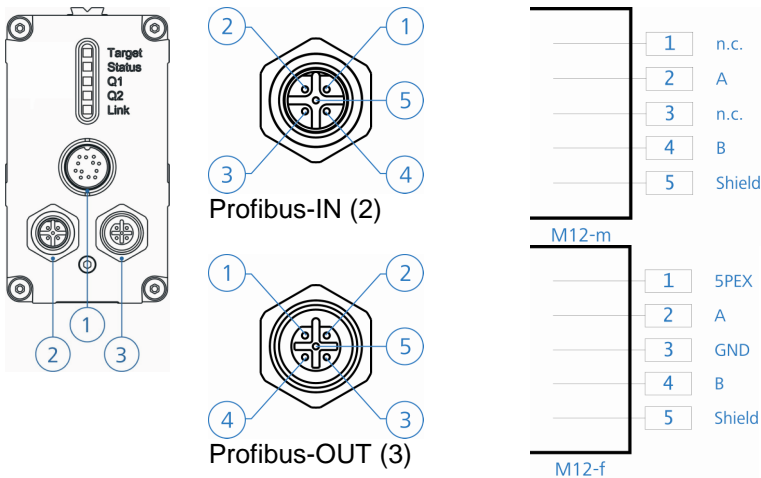

Figure 23 Profibus connection diagram LDM301P M12 connector

5.6.9 Profibus-Parameter

With the help of a GSD-file, a PB master creates parameters for the slave, and has to send these data at least once to the slave before the slave can be used for the cyclical data exchange. The slave is programmed with sufficient tolerance for being usable only with the 7 byte standard PB parameters (also without profile specific user parameters).

Interface Description

Name	Description
Class 2 function:	Selection of the slave type according to the encoder profile.
Commissioning Diagnostics:	Send more than the 6 byte standard diagnosis (16 Byte as Class1 Slave, 77 Byte as Class 2 Slave)
Measure mode:	Operating mode (Trigger) of the laser (DF,DT)
Trigger delay and level:	Values are transferred directly to the command TDx x (only with DF extern)
Averaging:	The value is transferred to the command SAn (number of the values for the mean value determination)
Measurement frequency:	Number of measurements per second (1 ... 2000 bzw. 10000) is transferred to the command MFn.
Offset:	An offset can be added to the measurement value (correction). The offset value is not transferred to the laser module, but is directly handled in the PB assembly group.
Scale factor:	Scaling factor $-10.0 \dots +10.0$. Up to 5 decimal places are processed.
Error mode:	Selection of the distance value in the event of an error.
Pilot Laser:	The pilot laser can be set to On, Off or Blinking.
Measurement window:	Set the start and the end of the measurement window.
Diagnostic interval:	0= send diagnosis data only in case of alarm 1..10000 = send diagnosis data every n x 100ms
Alarm 1/2:	Switching threshold for the output n in distance units -- transferred to the command Qn.
Alarm active range 1/2:	+/- range for the switching outputs in distance units -- transferred to the command Qn.
Alarm hysteresis 1/2:	+/- hysteresis for the switching outputs in distance units -- transferred to the command Qn.
Alarm level active range 1/2:	0 or 1 for the switching outputs in the active range -- transferred to the command Qn.

Table 9 Explanation Profibus parameters

Octet	Bit	Type	Output
1		byte	station status (Profibus default)
2		byte	wd_fact_1/watch dog (Profibus default)
3		byte	wd_fact_2 (Profibus default)
4		byte	min_tsdr (Profibus default)
5..6		word	ident number (Profibus default)
7		word	slave diag (Profibus default)
8		word	slave diag (Profibus default)

Interface Description

Octet	Bit	Type	Output
9	0	bool	unused
	1	bool	class functionality on/off
	2	bool	commissioning diagnostic on/off
	3	bool	unused
	4	bool	reserved for future use
	5	bool	reserved for future use
	6 7	bool bool	reserved for manufacturer reserved for manufacturer
			class 2 parameter
10..13		unsigned 32	unused
14..17		unsigned 32	unused
28..25		8 byte	unused
			manufactory specific parameter
26	0	bool	unused
	1	bool	trigger level 0:H → L 1:L → H [TDx y]
	2..3	2 bit	error reaction 0..2 [SEnn] 0:last valid value, 1:min value, 2:max value
	4 5..7	bool 3 bit	0:-non, 1:write EEPROM (store all parameter) measure mode [0:DF 1:DT 2:VT]
27..28		short	measure frequency [MFnn] 1..10000
29..32		signed 32	trigger delay [TDx..] 0..1000
33..36		signed 32	display offset [OFnnnn] +/-1000000
37..40		signed 32	output 1 switch limit 0..5000000 [Q1w..]
41..44		signed 32	output 2 switch limit 0..5000000 [Q2w..]
45..48		signed 32	output 1 hysteresis -5000000..5000000 [Q1..y..]
49..52		signed 32	output 2 hysteresis -5000000..5000000 [Q2..y..]
53..54		word	diag update time in 0.1 sec
55..56		short	average time [SAnn] 1..10000
57..60		signed 32	scale factor [SFnn] n*0.00001 (1.0 = 100000)
61..64		signed 32	active output 1: 0..5000000 [Q1..x..]
65..68		signed 32	active output 2: 0..5000000 [Q2..x..]
69	0	bool	level active range 1: 0/1
	1	bool	level active range 2: 0/1
	2..3	2 bit	mode of pilot laser: 0..3
	4..7	3 bit	unused
70..73		signed 32	measure window x
74..77		signed 32	measure window y
78..81		signed 32	analogue x
82..85		signed 32	analogue y

Table 10 Profibus parameter

Because of the LDM301P is a linear encoder for measuring absolute distances the parameters "code sequence", "scaling function control", "measuring units per revolution" and "measuring range in measuring units" are ignored.

5.6.10 Diag Common

The (general) diagnosis data correspond entirely to the profile standard, and will be updated with every Profibus-Diagnosis-Request. The Common Diag-data require the class 2 functionality and the Commissioning diagnostics function. In the event of errors (Enn), an alarm is issued as extended diagnosis which contains all diagnosis data. To see the current temperature and operating time, the diagnosis interval has to be set $\neq 0$. A diagnostic Interval of 100 leads to a data update every 10 sec.

Please observe that the laser has to capture and transmit a value in the DF modes, i.e. temperatures are only transferred if values are captured.

5.6.11 Diag Alarm

Error messages of the laser are sent as unique Ext. Diag. The alarms are not saved.

E98 shows problems with the internal communication. If errors occur, they are reported as Ext. Diag and then please try to activate the laser again.

5.6.12 Diagnostic Data

Class 2 functionality	Commissioning diagnostic	Diagnostic information
-	0	6 byte Normal-Diagnose
0	1	16 byte Class 1 - Diagnose
1	1	63 byte Class 2 – Diagnose

Table 11 Profibus diagnostic data length

Interface Description

Octet	Bit	Type	Input
1		byte	diag state 1 (Profibus default)
2		byte	diag state 2 (Profibus default)
3		byte	diag state 3 (Profibus default)
4		byte	diag state 4 (Profibus default)
5..6		word	slave diag (Profibus default)
			class 1 diagnostic
7		byte	extended diag. header length (class 1:0Ahex, class 2:39hex)
8		byte	alarms - unused
9	0	bool	unused
	1	bool	class functionality on/off
	2	bool	commissioning diagnostic on/off
	3	bool	Unused
	4	bool	reserved for future use
	5	bool	reserved for future use
	6	bool	reserved for manufacturer
	7	bool	reserved for manufacturer (operation status: para. byte 9)
			class 2 diagnostic
10		byte	encoder type (=7 absolute linear encoder)
11..14		unsigned 32	single turn resolution = 100000nm = 0.1mm
15..16		unsigned 16	no. of distinguishable revolutions – unused (=0)
17	0	bool	E98 – Timeout SIO
	1	bool	E99 – Unknown Error
18..19	0	bool	E02 – No Target
	1	bool	E04 – Laser defect
20..21		word	warnings – unused (=0)
22..23		word	warnings – unused (=0)
24..25		word	profile version (1.1 = 0110 hex)
26..27		word	software version (1.11 = 0111 hex)
28..31		unsigned 32	operating time (of laser), in 0.1 h
32..35		signed 32	offset value (see output data)
36..39		signed 32	manufacture offset – unused (=0)
40..43		unsigned 32	measuring units per revolution – unused (=0)
44..47		unsigned 32	measuring range – unused (=0)
48..57		10 byte	serial number
58..59		word	reserved for future use
60..61		short	laser temperature in 0.1 °C
62..63		short	signal strength

Table 12 Profibus diagnostic data

5.6.13 Cyclic data exchange – Input (Slave → Master)

The localization data from the LDM301P are signed. With the SF parameters (scale factor) the signs can be inverted. The resolution is also determined by SF.

The arrangement of the octet in the telegrams is Profibus-compliant (big endian), e.g. the MSB comes first and the LSB last.

4 byte input:

Octet	Type	Input
1..4	signed 32	distance value

8 byte input and mode VT:

Octet	Type	Input
1..4	signed 32	distance value
5..8	signed 32	speed value

Table 13 Profibus Input

5.6.14 Cyclic data exchange – Output (Master → Slave)

The most significant bit in the preset value (32 bit) determines the validity of the preset.

Octet	Type	Output
1..4	signed 32	Preset-Value Normal Mode: MSB = 0 (bit 31) Preset Mode: MSB = 1 (bit 31)

Table 14 Profibus Output

With the preset value, the actual value can be set to a desired value. This offset is used internally as offset M_{Offset} . By setting the bit 31, the offset value can be changed. It applies the following:

- M_{DataEx} output value for cyclic data exchange
- M_{Laser} value determined by the laser measurement
- M_{Offset} internally calculated offset
- M_{Preset} with the preset function of transferred value

- Cyclical calculation of: $M_{DataEx} = M_{Laser} + M_{Offset}$

- The value M_{Offset} is not permanently stored in LDM301P, it will get lost if you disconnect the device. The offset can be written directly as a parameter Octet 32..35.
- If the Bit 31 of M_{Preset} is set, the new M_{Offset} is calculated, so the following formula is valid: $M_{\text{Preset}} = M_{\text{Laser}} + M_{\text{Offset}}$.

The offset value can be read in the diagnostic data as an octet 30..33.

6 Installation

6.1 Preparation Work before the Installation

- Remove the packaging of the LDM301
- Check the delivery scope for completeness
- Check the device and the accessories for damages
- Check the connections and the cables for damages

6.2 Checklist for Installation Works

The following table shows an example procedure for commissioning the LDM301; other procedures of commissioning may also be possible. The application-specific wiring is a prerequisite. The user is responsible for the installation of the wiring, and for the application-specific parameterization of the Profibus (LDM301P), especially the Slave-address.

No.	Workstep
1	Unpack the LDM301 and check it for damages.
2	Install the LDM301 at the target location, and use the 3 M4-tapped holes at one of the 3 possible surfaces of support of the LDM301 (see 4.6)
3	Plug the interface cable only when there is no voltage impressed; bolt the cables tightly.
4	Plug the Profibus- or SSI-connections and bolt them on tightly (LDM301P or LDM301S).
5	Switch on the supply voltage; the status LED has to shine green.
6	Parameterize the LDM301 with the PC program LDMTTool via RS232 / RS422.
7	Align the LDM301 towards a target, use the sight pointer or the additional sight appliance on the 11 mm rails.
8	Activate pilot laser stop any distance measurement mode (ESC)
9	Adjust to the target by using the visible laser (pilot laser)
10	Fix the LDM301
11	Start distance measurement (Measurement laser is switched on; Pilot laser is turned off automatically).
12	Parameter read out and save to disk

Table 15 Installation of LDM301

Installation

Before switching on the power supply on make sure that all cable ends are protected against short circuit effects!

Connect cable terminals as required for the particular operating mode. To prevent short circuits, you should seal unused cable ends!

For starting up, a PC with RS232 or RS422 data interface and a terminal program are required. We recommend the Windows program LDMTOOL Version 4.5 or higher (see Figure 24).

Converter from RS232 to USB are available as accessories.

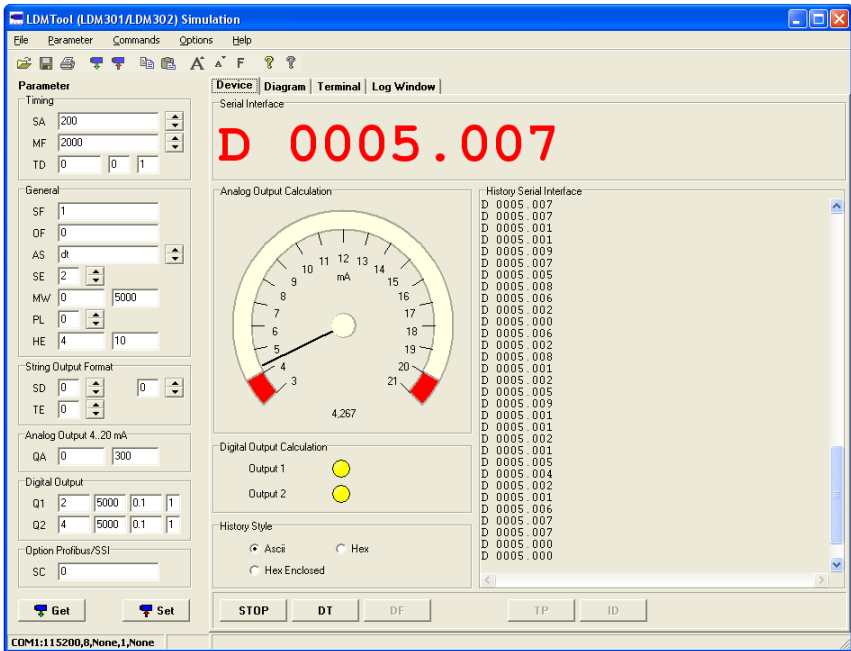

Figure 24 Program LDMTool

7 Description of Commands

7.1 Identification

7.1.1 ID –Identification

In response to an ID command, the LDM 301 outputs its manufacturing data in this order: product type, firmware version, firmware data, firmware time, serial number, date of manufacture and time of manufacture.

Example:

```
LDM 301 1.5.0(R) 03.07.2010 11:31 060001 11.04.2010 08:56
```

7.1.2 ID? – Online-Hilfe

On triggering an ID? command, an overview of all available operations and parameters will be displayed to the user. These are explained in the following sections.

```
DM[Enter].....single distance
DT[Enter].....continuous distance internal trigger
DF[Enter].....continuous distance external trigger
VM[Enter].....single velocity
VT[Enter].....continuous velocity internal trigger
TP[Enter].....internal temperature [°C]
HW[Enter].....hardware status
PA[Enter].....display parameter
AS[Enter]/ASxyz[Enter].....display/set autostart command
PL[Enter]/PLx[Enter].....display/set pilot laser
PR[Enter].....reset parameter
DR[Enter].....reset device
SF[Enter]/SFx[Enter].....display/set scale factor
OF[Enter]/OFx[Enter].....display/set user offset
SO[Enter].....set current distance to offset
MW[Enter]/MWx y[Enter].....display/set measure window
MF[Enter]/MFx[Enter].....display/set measure frequency
SA[Enter]/SAX[Enter].....display/set average value
TD[Enter]/TDx y[Enter].....display/set trigger delay level
SE[Enter]/SEx[Enter].....display/set error mode
Q1[Enter]/Q1w x y z[Enter]..display/set digital output Q1
Q2[Enter]/Q2w x y z[Enter]..display/set digital output Q2
QA[Enter]/QAx y[Enter].....display/set analog output QA
BR[Enter]/BRx[Enter].....display/set baud rate RS232/422
SD[Enter]/SDx y[Enter].....display/set data format RS232/422
TE[Enter]/TEx[Enter].....display/set terminator RS232/422
SC[Enter]/SCx[Enter].....display/set SSI format
HE[Enter]/HEX y[Enter].....display/set heater threshold levels
```

Figure 25 Online Help (Command ID?)

7.2 Operation Mode

7.2.1 DM – Single distance measurement

The LDM301 carries out exactly one measurement and waits for new commands afterwards.

The duration of a measurement depends on the number of the set measurement values SA and the set measurement frequency MF.

The time between sending the command DM and the output of the measurement value is 500 μ s maximum.

7.2.2 DT – Continuous distance measurement

Continuous distance measurement is carried out and can be stopped with the suitable command (RS232/RS422: Escape = 0x1B).

The output rate of the measurement depends on the number of the set measurement values SA and the set measurement frequency.

7.2.3 DF – Measure single distance with external triggering

The operating mode DF must be set for the LDM301. When an external trigger signal is received, the device carries out exactly one measurement and waits afterwards for the next trigger event in the operating mode DF.

The operating mode must be terminated with the corresponding command (RS232/RS422: Escape = 0x1B9).

The trigger event has to be applied to the external trigger connection (see chapter 5.4).

The intervals between the single measurements depend on the set measurement values SA, the set measurement frequency MF and the set trigger delay TD.

7.2.4 VM – Single speed measurement

The LDM301 carries out 25 single speed measurements from which the speed is calculated.

The duration of the measurement depends on the number of the set measurement values SA and the set measurement frequency MF.

For the output of the speed measurement data, at least 9 valid distance measurements are necessary. If a distance value is output additionally, this value always denotes the first valid distance value that was used for the speed calculation.

7.2.5 VT – Continuous speed measurement

The LDM301 carries out a continuous measurement. From 25 single measurements, the speed value is calculated. The continuous speed measurement can be stopped with the command (RS232/RS422: Escape = 0x1B).

The interval between the single measurements depends on the set measurement value SA and the set measurement frequency MF.

7.2.6 Precision of the speed measurement

The precision of the speed measurement is derived from the following formula:

$$\sigma_v = \sigma_d \cdot \frac{f}{N \cdot \sqrt{N}} \cdot \frac{1}{\sqrt{1300}}$$

The following parameters apply:

- f Measurement frequency (parameter MF)
- N Average value (parameter SA)
- σ_d Standard deviation distance measurement (single shot without averaging)
- σ_v Standard deviation speed measurement

The duration of the speed measurement amounts to:

$$t = \frac{25 \cdot N}{f}$$

Assuming the standard deviation of $\sigma_d = 3\text{cm}$ for a single distance measurement, the following table results:

f [Hz]	N	σ_v [m/s]	t [s]
2000	1	1.664	0.013
2000	5	0.149	0.063
2000	10	0.053	0.125
2000	15	0.029	0.188
2000	20	0.019	0.250
2000	25	0.013	0.313
2000	30	0.005	0.625

Table 16 Standard deviation for speed measurement

7.3 Status

7.3.1 TP – Internal device temperature

The LDM301 outputs the internal device temperature via the serial interface and the Profibus interface. The data are output in Degree Celsius (°C).

7.3.2 PA – Display of all parameters

A list of all parameters is output via the serial interface.

Example:

```

measure frequency[MF]           2000hz
trigger delay/level[TD]        0.00msec 0 0
average value[SA]              20
scale factor[SF]                1.000000
measure window[MW]             1.000 300.000
distance offset[OF]            0000
error mode[SE]                  1
digital out[Q1]                 20.000 10.000 1.000 1
digital out[Q2]                 1.000 30.000 0.500 1
analog out[QA]                  1.000 300.000
RS232/422 baud rate[BR]        115200
RS232/422 output format[SD]    dec (0), value (0)
RS232/422 output terminator[TE] 0Dh 0Ah (0)
SSI output format[SC]          bin (0)
pilot laser [PL]                2
autostart command[AS]          dt
heater threshold levels[HE]     4 10
    
```

Figure 26 Display of all parameters (command PA)

7.3.3 HW – Hardware diagnosis

A device specific list of characteristics and measurement variables is output. Explanation of the items in the hardware status:

Item	Description
TCB	Temperature controller board
TRE	Temperature receiver
VUV	Supply voltage
VDD	Internal voltage digital 5 V
VCC	Internal voltage digital 3 V
VTDC	Control voltage timer measurement circuit
VCP	Detection threshold receiver signal
VHV	High voltage laser
VPT	Output voltage transmitter identification
VREF	Input voltage transmitter identification
QCLK	Deviation quartz frequency internal

Table 17 Description for hardware diagnosis

7.4 Setup Parameter

The parameters are set via the serial interface. With the terminator 0x0D, the command is transferred to the LDM301.

If commands have only one parameter, the parameter is inserted directly or separated by a blank space.

If commands have several parameters, these parameters will be separated by a blank space 0x20.

7.4.1 AS – Auto start function

The auto start function defines the behaviour of the LDM301 after a cold start. After the start, the LDM carries out the commands automatically and sends the data via the serial interface.

Query:	AS
Set:	ASs
Parameter value range s:	ID, ID?, DM, DT, DF, VM, VT, TP, HW, PA, MF, TD, SA, SF, MW, OF, SE, Q1, Q2, QA, BR, SD, TE, BB, AB, SC, PL, AS
Standard:	DT

7.4.2 PL – Pilot Laser

With the command PLx, the behaviour x of the pilot laser is parametrized.

Query: PL
 Set: PLx
 Parameter value range x: 0, 1, 2, 3 (Table 18 Pilot laser PLx, x)
 Standard: 0

x	Behaviour of the Pilot Laser
0	Off
1	On
2	Blinking (2 Hz)
3	Blinking (5 Hz)

Table 18 Pilot laser PLx, x value

7.4.3 PR – Reset to factory settings

All parameters are reset to factory settings. Except for the baud rate! We do not recommend to use this command. Afterwards the device must be programmed new (auto start, scaling analogue and output etc.).

Parameter for firmware version 1.5:

```

measure frequency[MF] ..... 2000(max 2000)hz
trigger delay/level/mode[TD] ..... 0.00msec 0 0
average value[SA] ..... 20
scale factor[SF] ..... 1.000000
measure window[MW] ..... -5000.000 5000.000
distance offset[OF] ..... 0.000
error mode[SE] ..... 1
digital out[Q1] ..... 0.000 0.000 0.000 1
digital out[Q2] ..... 0.000 0.000 0.000 1
analog out[QA] ..... 1.000 300.000
RS232/422 baud rate[BR] ..... 115200
RS232/422 output format[SD] ..... dec (0), value (0)
RS232/422 output terminator[TE] ..... 0Dh 0Ah (0)
SSI format[SC] ..... bin (0)
pilot laser [PL] ..... 2
autostart command[AS] ..... ID
heater threshold levels[HE] ..... 4 10
    
```

Figure 27 Parameter reset (command PR)

7.4.4 DR – Release cold start

DR carries out the cold start of the LDM301 and basically simulates an interruption of the voltage. This command is useful for example when the “Autostart”-command was changed.

7.4.5 SF – Scaling factor

SF_x enables the scaling of the output measurement value by the parameterization of the factor x.

Query:	SF
Set:	SF _x
Parameter value	-10 ... -0.001 and 0.001 ... 10; resolution:
range x:	0.000001
Standard:	1.000000

7.4.6 OF – Offset

With OF, the user specific offset x is parameterized. This value is added to the measurement value.

Query:	OF
Set:	OF _x
Parameter value	float32; resolution: 0.001
range x:	
Standard:	0.000

No plausibility test of the set offset is carried out within the LDM301; the user is responsible to set the correct parameterization!

7.4.7 SO – Set offset

With the parameter SO, a single distance measurement is carried out and set as OF (Offset). SO can only be executed, in this way, it is not a parameter in the strict sense.

SO is used for the zero-adjustment of applications, systems, processes etc.

7.4.8 MW – Measurement window

The range of the measurement window is parameterized with MW, which outputs only measurement values within the window, starting with x and terminating with y.

The measurement window is used e.g. for:

- Blanking out interfering objects before and behind a measurement range
- Setting an effective measurement range

The detection of an object in front of or behind a measurement window will result in the output of an invalid measurement value.

Query:	MW
Set:	MWx y
Parameter value range x:	float32; resolution: 0.001
Parameter value range y:	float32; resolution: 0.001
Standard:	0.000 ... 5000.000

No plausibility test for the set measurement window will be carried out in the LDM301; the user is responsible for carrying out the correct parameterization!

7.4.9 MF – Measurement frequency [Hz]

With the command MF, the number x of the single impulses to be sent per second can be parameterized.

Query:	MF
Set:	MFx
Parameter value range x:	1 ... 2000; resolution: 1
Standard:	2000

MF1000 e.g. means that 1000 single impulses are sent per second. The measurement time and the transmission of the measurement result via a serial interface also depend from the parameter SA.

Description of Commands

Examples:

MF1000, SA1000:

Measurement time = 1 s (output of 1 measurement value per second)

MF2000, SA1000:

Measurement time = 0.5 s (output of 2 measurement values per second)

MF2000, SA20000:

Measurement time = 10 s (output of 1 measurement value every 10 seconds)

7.4.10 SA – Average value

With the command SA, the number x of the single measurement values are parameterized. From these values, a mean value will be calculated for a measurement. SA is directly dependent from the parameter MF (see also 7.4.9).

Query: SA
Set: SAx
Parameter value range x: 1 ... 30000; resolution: 1
Standard: 200

The dispersion of the measurement values can be reduced by calculating the mean value:

$$\sigma_{SA} = \frac{\sigma_1}{\sqrt{SA}}$$

Where:

σ_{SA} Dispersion after mean value calculation
 σ_1 Dispersion of the single measurement value (60mm)
SA Number of mean values

f [Hz] = MF	SA	Result for Output frequency [Hz]	σ_{SA} [mm]
2000	1	2000	60
2000	2	1000	43
2000	4	500	30
2000	20	100	14
2000	200	10	5

Table 19 Streuung Entfernungsmessung

7.4.11 TD – External trigger delay / level / mode

With the command TD, the behaviour in the external trigger mode (DF) is parameterized.

- x is the delay for trigger an single measurement in milliseconds
- y denotes the edge for triggering:
 - 0: the trigger is released at a falling edge (from High to Low).
 - 1: the trigger is released at a rising edge (from Low to High)
- z sets the mode with respect to SA:
 - 0: a trigger causes a laser pulse and after SA measurements one output will follow
 - 1: a trigger causes a number of SA laser pulses and after that one output

Query:	TD
Set:	TDx y z
Parameter value range x:	0 ... 300.00 msec; resolution: 0.01 msec
Parameter value range y, z:	0 or 1
Standard:	0.00 0 0

If a trigger impulse is received before the actual measurement process is finished, the LDM301 ignores the new trigger impulse. A new measurement procedure is released with the following trigger impulse. The parameter z is not valid for device LDM301P.

7.4.12 SE – Error Mode

SE parameterizes the behaviour of the switching outputs Q1 and Q2 and of the analogue output QA in case of erroneous measurements, as well as the device state after carrying out a single measurement.

Query:	SE
Set:	SEx
Parameter value range x:	0, 1, 2 (Table 20 Error Mode SEx, values for x)
Standard:	1

x	Q1, Q2 (z=0)	Q1, Q2 (z=1)	QA
0	Last value	Last value	Last value
1	High	Low	3 mA
2	Low	High	21 mA

Table 20 Error Mode SEx, values for x

No plausibility test for the set error mode is carried out in the LDM301; the user is responsible to set the correct parameterization.

7.4.13 Q1/Q2 – Switching output

Commands Q1/Q2 parameterizes the behaviour of the switching outputs Q1 or Q2 (see text and diagram of the switching behaviour in chapter 5.2). It can be parameterized the start w of the measurement range when the output switches, the length x of the measurement range and the hysteresis y and the logical behaviour z.

Query:	Q1 / Q2
Set:	Q1w x y z / Q2w x y z
Parameter value range w:	float32; resolution: 0.001
Parameter value range x:	float32; resolution: 0.001; $x > 0$; $x > y$
Parameter value range y:	float32; resolution: 0.001; $y > 0$
Parameter value range z:	0 or 1
Standard:	Q1: 2 5000 0.1 1 Q2: 4 5000 0.1 1

Output	VT Speed measurement	DT, DM, DF Distance measurement
Q1	Speed	Distance
Q2	Distance	Distance

Table 21 Function of the switching outputs under different modes

No plausibility test for the settings of Q1 resp. Q2 are carried out; the user is responsible for setting the correct parameterization!

When carrying out speed measurement using an LDM301P with the Profibus interface, please observe that the switching threshold w for Q1 can only be set with positive numbers (target departs from the LDM301P).

7.4.14 QA – Analogue output

The command QA parameterizes the behaviour of the analogue output QA (see 5.3).

Available for setting are the lower limit x and the upper limit y of a current range from 4 to 20 mA. The lower limit may be smaller or greater than the upper limit. Accordingly, the current range will reverse.

Inputs of identical limits will be ignored and not accepted.

Query:	QA
Set:	QAx y
Parameter value range x:	float32; resolution: 0.001
Parameter value range y:	float32; resolution: 0.001
Standard:	0 50.000

No plausibility check for the QA-settings will be carried out in the LDM301; the user is responsible for setting the correct parameterization! The measurement window MW (see 7.4.8) is also valid for the analogue output.

7.4.15 BR – Baudrate

BR enables the change of the serial baud rate x.

A cold start is not necessary after changing the baud rate!

Query:	BR
Set:	BRx
Parameter value range x:	9600, 19200, 38400, 57600, 115200, 230400 or 460800
Standard:	115200



Setting a very high baud rate implies a risk. Some computers for example cannot support a baud rate of 460800 or higher. If the baud rate is set by the command BR460800, communication is no longer possible without a compatible interface, i.e. the baud rate cannot be reset to a lower value without a PC support this baud rate!

7.4.16 SD - Output format serial interface

SD parameterizes the format x and content y of the output of the serial interface for distance and speed measurements. The format can be decimal (ASCII), hexadecimal (ASCII) or binary.

Query:	SD
Set:	SDx y
Parameter value range x:	0, 1, 2
Parameter value range y:	0, 1, 2, 3 (Table 22 Serial output format SDy, parameter y)
Standard:	0 0

The parameter y allows additional to the measurement value the output of signal strength and / or the output of temperature.

Description of Commands

y	SD0 y Decimal	SD1 y Hexadecimal	SD2 y Binary
0	Measurement value	Measurement value	Measurement value
1	Measurement value, Signal strength	Measurement value, Signal strength	Measurement value, Signal strength
2	Measurement value, Temperature	Measurement value, Temperature	Measurement value, Temperature
3	Measurement value, Signal strength, Temperature	Measurement value, Signal strength, Temperature	Measurement value, Signal strength, Temperature

Table 22 Serial output format SDy, parameter y

Explanation binary output format

Distance: 3 Byte,

MSB = Bit 7

MSB of Byte 2 always 1

MSB of Byte 1 and 0 always 0

Measurement data: Byte 0 and 1 = Bit 6 ... Bit 0

Coding: Two's compliment

Scaling factor binary values to decimal values: 1/1000

Signal strength: 1 Byte

MSB = Bit 7

MSB of Byte 0 always 0

Measurement data: Byte = Bit 6 ... Bit 0

Scaling factor binary values to decimal values: 128

Temperature: 2 Byte

MSB = Bit 7

MSB of Byte 1 and 0 always 0

Measurement data: Byte = Bit 6 ... Bit 0

Coding: Two's compliment

Scaling factor binary values to decimal values: 1/10

Speed: 3 Byte + 2 Byte for distance

MSB = Bit 7

MSB of Byte 2 always 1

MSB of Byte 1 and 0 always 0

Measurement data: Byte = Bit 6 ... Bit 0

Coding: Two's compliment

Scaling factor binary values to decimal values: 1/1000

7.4.17 TE – Terminator for the serial interface

The command TE parameterizes the termination for the serial interface data when carrying out distance and speed measurement. The output format SD0 y is necessary.

The termination for all outputs is always CRLF (0x0D0A)!

Query: TE
 Set: TEx
 Parameter value range x: 0 ... 9; resolution 1 (Table 23 Termination character(s) TEx, parameter x)
 Standard: 0

x	0	1	2	3	4	5	6	7	8	9
Hex code	0x0D0A	0x0D	0x0A	0x02	0x03	0x09	0x20	0x2C	0x3A	0x3B
Description	CR LF	CR	LF	STX	ETX	Tabulator	Blank space	Comma	Colon	Semicolon

Table 23 Termination character(s) TEx, parameter x

7.4.18 SC – Format SSI

SC parameterizes the format x of the SSI codes (see 5.5).

Query: SC
 Set: SCx
 Parameter value range x: 0 or 1
 Standard: 0

SCx x=0...binary, 25 bit (24 bit and 1 bit valid)

x=1...gray, 25 bit (24 bit plus 1 bit valid)

Bitfolge:

24	23	2	1	0	
MSB			Bit 1 – 24 Distance (depending from the scaling factor SF)		LSB	*)

*) Bit 0: Valid bit

7.4.19 HE – Threshold heating

HE parameters set thresholds for the switching on and off the internal heating.

Query:	HE
Set:	HEx y
Parameter value range x:	-60 ... 40 (°C)
Parameter value range y:	-60 ... 45 (°C)
Standard:	x = 4 y = 10 (°C)

For the switching of the heating, the internal temperature measured with the set parameters is compared.

Internal temperature < x (HeatON), heating is switched on

Internal temperature > y (HeatOFF), heating is switched off

For the parameters must be considered: x (HeatON) <= y (HeatOFF)!

8 Maintenance

8.1 Maintenance by the user

Please observe the following advice:

- Dust on optical glass surfaces (transmitter and receiver optics) can be removed with a blower brush. The surfaces must not be cleaned using cleaning agents containing organic solvents. If soilings persist, please contact the manufacturer.
- Isopropanol is suitable for cleaning the device. Do not use any solvents.
- Do not open the device, otherwise the warranty obligations shall cease to apply.
- Do not loose any screws at the device.

8.2 Firmware Update

Firmware-Updates of the sensor electronics of the LDM301 may only be carried out by the manufacturer.

8.3 Repair

In case that repair work is necessary, send the device to your expert dealer or to the manufacturer or contact us by phone or E-mail. The manufacturer address is found below. Ensure the safe packaging and provide information about the conditions of use (applications, installation conditions, environmental conditions).

9 Malfunction & Error Messages

9.1 Malfunction

Error	Cause	Action for removal
No data via RS232 or RS422	Faulty interface configuration	Check interface configuration
Device error (Ext. Diagnosis)	Hardware problems	Send LDM301P for repair Contact technical support

Table 24 Malfunctions

9.2 Error Codes

Code	Cause	Action for removal
E02	No target	Observe measurement distance; reflectivity of the target is too low.
E04	Laser defect	Send LDM301 for repair Contact technical support

Table 25 Error codes

9.3 Error Status

Error status	Cause	Action for removal
Red status LED of status display lights	Read error message via RS232 or RS422 interface	Send LDM301 for repair Contact technical support

Table 26 Error status

10 Options

10.1 RS232 Cable

For parameterization an optional programming cable is available to link the LDM 301 with a PC (COM port, RS 232). The use of PC software LDMTTool is recommended.

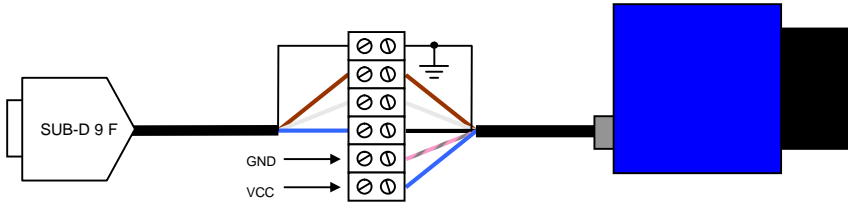

Figure 28 PC-Interface cable with power supply

Nr. SUB-D 9 F	Colour code	Name SUB-D 9 F (RS 232, PC COM)
Shield	-	Cable shield
3	brown	TxD
2	white	RxD
5	blue	GND

Table 27 Connection of programming cable PC sided

Pin LDM 301	Colour code	Name LDM 301
Shield	-	Cable shield
A	white	TxD
B	brown	RxD
J	black	GND
G	blue	VCC (+10 V ... +30 V DC)
L	grey/pink	GND

Table 28 Connection of programming cabiLDM301 sided



Attention: Heed cable colours:

blue – VCC and gray/pink – GND!

Please use only high quality shielded cable.

RS232 Cable: TxD and RxD are necessary to cross.

10.2 Connection box TCBLDM

A junction box with built-in terminal block and accessories are available optionally.

10.3 Adjustment bracket

The adjustment bracket facilitates the alignment of the device to the target. It allows a rotation of $\pm 5^\circ$ in two axes.

10.4 Dot Sight AD30

The AD30 is designed to facilitate alignment of the measuring object. The sight is attached with its 11 mm guide with the rail on the top of the LDM301. The sight must be adjusted after assembly and before use.



Figure 29 Red dot sight

It is recommended to carry out the adjustment of the dot sight to the measurement beam of the LDM301 in the following way:

- Connect RS232 to the PC
- Start the program (LDMTTool)
- Use mode DT with parameter SD0 1 (distance + signal strength)
- Set the sight switch on (0 = off)
- With LDM301 target an edge of a highly reflective target (for example traffic signs).
- Check the signal strength of the LDM301:
 - Laser beam on traffic signs = strong signal, target LED is green, signal strength > 1500
 - Laser beam not on traffic signs = weak signal, target LED is red, signal strength < 1000
- Vertical and horizontal adjustment of the rear sight on the edge of the target by using the 2 screws (red dot adjust to edge).

- Check the results:
 - Red dot and laser beam on the target results in strong signal.
 - Red dot and laser beam near the target, signal strength is lower than before.

10.5 Adapter plate

An adapter plate can be delivered for attaching the LDM301. This adapter plate is bolted to the case back of the LDM301, and offers different options for adapting the device, e.g. a tripod thread $\frac{1}{4}$ -20 UNC.

When replacing the LDM300C by an LDM301, the existing fixing holes can be further used.

Thread data LDM301:

LDM301 receiver optics: M52 x 0.75; thread depth 5 mm

LDM301 receiver optics: M41 x 0.5; thread depth 5 mm

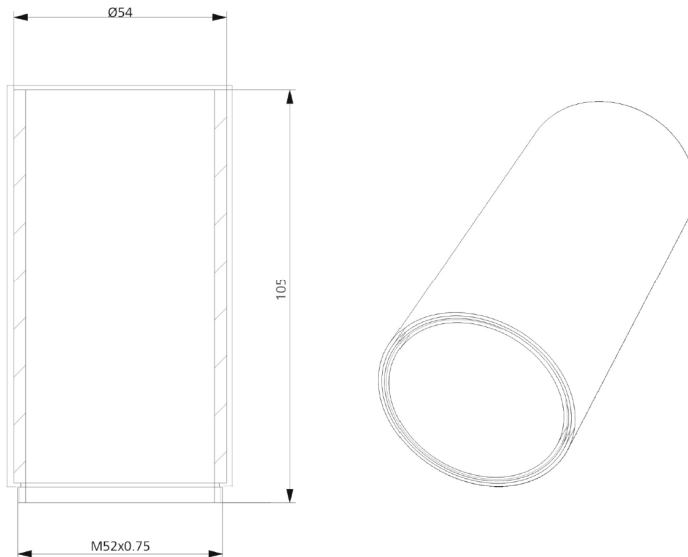

Figure 31 Dust protection tube

10.7 Protection Housing

A protection stainless steel housing with integrated terminal block is optional available.



Figure 32 Protection Housing

10.8 Software LDMTTool

A demo version of the software LDMTTool is included. By purchasing a license number, this will become the full version. Parameterization and numerical display of measured values can be used indefinitely also in the demo version (see Figure 24 Program LDMTTool).

11 Order Codes

Order Codes	Name
10-2004-00	LDM301
10-2004-01	LDM301 with Option 10kHz
10-2004-02	LDM301 with Option 10mrad
10-2004-03	LDM301 with Option 10 kHz und 10mrad
10-2005-00	LDM301/RS422
10-2005-01	LDM301/RS422 with Option 10kHz
10-2005-02	LDM301/RS422 with Option 10mrad
10-2005-03	LDM301/RS422 with Option 10 kHz und 10mrad
10-2006-00	LDM301S
10-2007-00	LDM301P
11-2000-00	Power supply 24V, 1A, Euro 1m
11-0001-00	USB-RS232 Interface Converter, 0,2m
12-2001-01	Connection Box for LDM301
12-2005-00	Adapter Plate LDM301
12-2006-00	Dot Sight AD30
12-2003-02	Protection housing for LDM301
12-2014-00	Adjustment bracket for LDM301
12-2016-00	Dust Protection Tube 100mm for LDM301
15-2001-00	RS232-Kabel D-SUB9F/Lüsterkl., 2m
15-2003-00	Main Cable LDM301, 2m
15-2003-01	Main Cable LDM301, 5m
15-2003-02	Main Cable LDM301, 10m
15-2005-00	Main Cable Connector LDM41/42A, LDM301
15-0000-00	Terminator for Profibus OUT
15-0014-00	Cable Plug Profibus OUT, 4-pin, B-coded
15-0015-01	Cable Connector Profibus IN, 5-pin, B-coded
12-2010-00	Reflective Foil Matt/White, A4
12-2011-00	Highly Reflective Silver Foil,A4
16-0000-00	ASTECH CD (LDM, VLM)
17-2000-00	License Number for PC-Software LDMSTool

Note: Several sensors are available as packages including sensor, cable, manual and CD (Set).

12 EC Declaration of Conformity



We herewith declare, represented by the signatories, that the following designated product

Laser Distance Meter LDM301

agree with the Directive of Electromagnetic Compatibility 2004/108/EG.
The following harmonized standards were considered:

IEC 61326-1:2005 Electrical equipment for measurement, control and laboratory use, EMC requirements Part1: General requirement (IEC 61326-1:2005); German Version EN 61326-1:2006

Rostock, 2010-10-18
ASTECH Angewandte Sensortechnik GmbH

A handwritten signature in blue ink, appearing to read 'Volker Ahrendt', is written over the printed name.

Volker Ahrendt
Managing Director

